



NEW MEXICO MEASURES
OF STUDENT SUCCESS AND
ACHIEVEMENT

M

S

S

A

NM-MSSA Spring 2021

Mathematics

Grade 7 • Practice Test



PLACE STUDENT
LABEL HERE



Mathematics Session 1

DIRECTIONS

Today you will take a test in mathematics. For this test, you will answer selected-response and constructed-response questions. Some of the questions may look different from test questions you have seen before, and some may ask about material that is new to you, but it is important to do your best. If you are not sure of the answer to a question, you should still try to answer it.

You may NOT use a calculator to answer the questions in this session.

1. Angie paid a total of \$750 for 10 tickets to a musical. The money was taken from her bank account.

Which expression represents the dollar amount that was taken from Angie's bank account?

- A $\frac{750}{10}$
- B $-75(10)$
- C $-\left(\frac{75}{10}\right)$
- D $750(10)$

2. This diagram shows a rectangular park with diagonals that represent sidewalks.

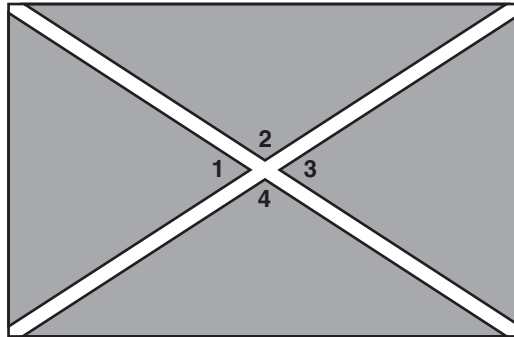

The measure of $\angle 1 = 66^\circ$. What is the measure of $\angle 2$?

- A 24°
- B 104°
- C 114°
- D 294°

SESSION

1

3. A piece of cheese is shaped like a right triangular prism.

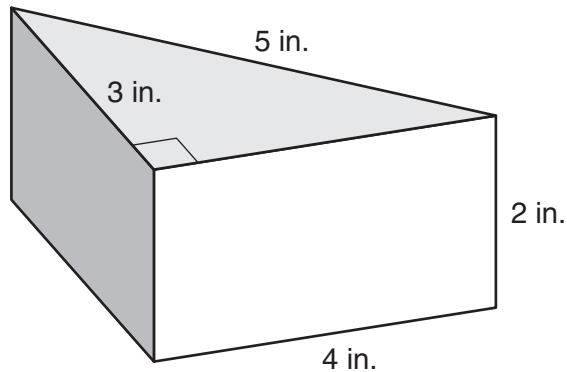

The **entire** surface of the cheese will be covered with a wax coating. What is the surface area of the piece of cheese?

- A 20 square inches
- B 26 square inches
- C 32 square inches
- D 36 square inches

4. A store is having a sale. Each item is on sale for half off the regular price, m . Which pair of equivalent expressions represents the sale price for any one item?
- A $0.5m$ and $m - \frac{1}{2}$
- B $0.5m$ and $m - \frac{1}{2}m$
- C $m - 0.5$ and $m - \frac{1}{2}$
- D $m - 0.5$ and $m - \frac{1}{2}m$
5. During a trivia game, a player receives 2 points for each correct answer and $-\frac{1}{2}$ point for each incorrect answer. During round 1, Annette answers 5 questions correctly and 6 questions incorrectly. What is Annette's score at the end of round 1?
- A -3 points
- B -1 point
- C 7 points
- D 13 points

6. Harry raised \$10 for each kilometer he walked in a walkathon. His goal was to raise at least \$300 on Saturday and Sunday. Harry raised \$50 on Saturday.

Which graph shows the distances, in kilometers, that Harry could have walked on Sunday to reach his goal?

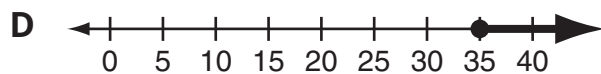
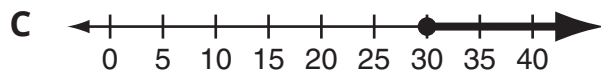
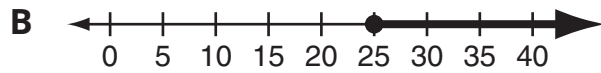
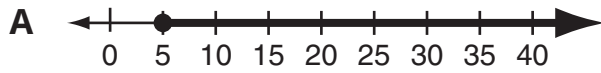

7. Students in a middle school entered their name in a raffle. The number of students in each grade level is shown in this bar graph.

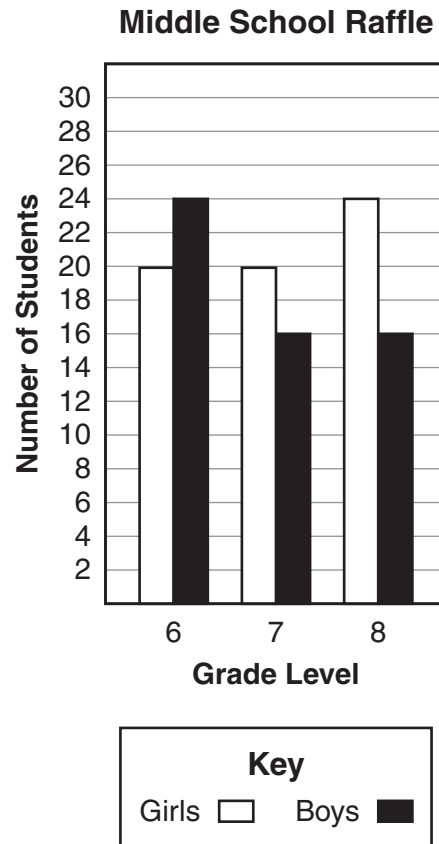
SESSION
1

Each student could enter his or her name only once. One student who entered the raffle will be selected at random.

What is the probability that the student selected will be a seventh-grade student? Use words or numbers to justify your answer.

8. Two points are shown on this number line.

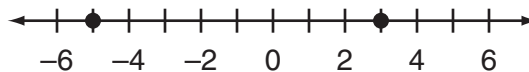

Which expression represents the distance between the two points?

- A $|-5| - |3|$
B $|3| - |-5|$
C $|-5 - 3|$
D $|3 - 5|$

Use the information below to answer questions 9 and 10.

Penelope won a contest. For her prize, she gets to reach into a bag of envelopes and take one envelope without looking. Each envelope has a cash prize. The bag contains these envelopes:

- 100 envelopes with \$10
- 50 envelopes with \$50
- 25 envelopes with \$100
- 15 envelopes with \$200
- 10 envelopes with \$500
- 1 envelope with \$1,000

SESSION

1



9. Penelope thinks that the probability of getting an envelope that contains \$10 is more likely than not. Which statement **best** explains whether Penelope is correct?
- A No, the probability that she will get an envelope with \$10 is less than 0.5.
 - B Yes, the probability that she will get an envelope with \$10 is less than 0.5.
 - C No, the probability that she will get an envelope with \$10 is greater than 0.5.
 - D Yes, the probability that she will get an envelope with \$10 is greater than 0.5.
10. Penelope claims this expression represents the probability that she will get an envelope with at least \$500.

$$\frac{10}{100 + 50 + 25 + 15 + 1}$$

Is Penelope's claim true?

- A Yes, her claim is true.
- B No, she should add 1 to the numerator.
- C No, she should add 1 to the numerator and 10 to the denominator.
- D No, she should add 1 to the numerator and subtract 1 from the denominator.



11. The motion of a snail is shown on this graph.

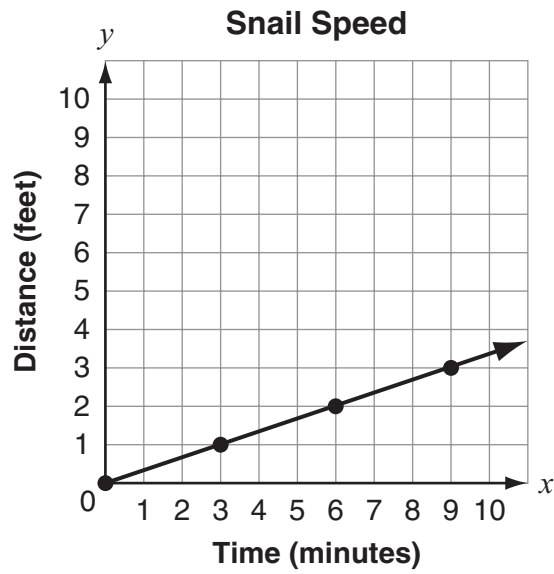

What is the speed of the snail's motion?

- A** 0 feet per minute
- B** $\frac{1}{3}$ foot per minute
- C** $\frac{1}{2}$ foot per minute
- D** 3 feet per minute

SESSION

1

12. In $\frac{1}{2}$ minute, Tamara's car traveled $\frac{3}{4}$ kilometer.

What was the rate, in kilometers per minute, of Tamara's car?

- A $\frac{3}{8}$ kilometer per minute
- B $\frac{2}{3}$ kilometer per minute
- C $1\frac{1}{4}$ kilometers per minute
- D $1\frac{1}{2}$ kilometers per minute
13. Thomas runs a 12.5-kilometer road race. There is water available for the runners every 2.5 kilometers except at the start.

How many water stops are there along the race?

- A 5
- B 6
- C 10
- D 15

- 14.** It costs Jan's family \$87 to rent 3 bikes for 4 hours. The cost includes a \$5 fee for each bike rental plus an hourly rate.

Which method can be used to check that the hourly rate is \$6?

- A** Multiply $6(4)$. Then add 5 to the product.
 - B** Multiply $6(4)$. Then add $3(5)$ to the product.
 - C** Multiply $3(6)(4)$. Then add 5 to the product.
 - D** Multiply $3(6)(4)$. Then add $3(5)$ to the product.
- 15.** An expression is shown.

$$32x - 120y$$

Which expression is equivalent?

- A** $8(4x - 15y)$
- B** $8(4 - 15)xy$
- C** $8y(4x - 15)$
- D** $8x(4 - 15y)$



- 16.** Kevin and Marlow were at track practice. One lap around the track is $\frac{2}{5}$ kilometer.
- Kevin ran 2 laps in 4 minutes.
 - Marlow ran 3 laps in 5 minutes.

Which student ran faster, in kilometers per minute?

- A** Kevin ran faster because $\frac{1}{5} < \frac{6}{25}$.
- B** Marlow ran faster because $4\frac{1}{6} < 5$.
- C** Kevin ran faster because $10 < 12\frac{1}{2}$.
- D** Marlow ran faster because $1\frac{2}{3} < 2$.

17. Nadine is researching summer camps. This double box-and-whisker plot shows the distribution of positive feedback for the same activities at two different camps.

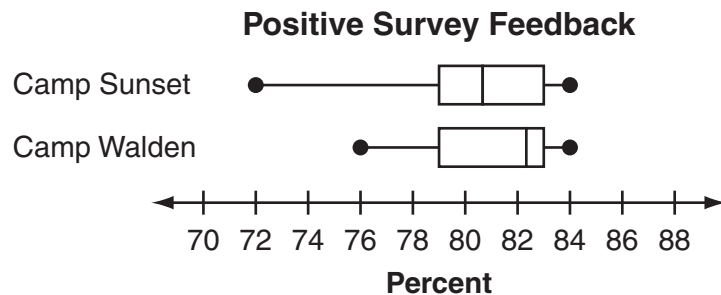

Based on these data alone, which camp should Nadine attend and why?

- A** Camp Sunset, because the feedback for the activities is more consistent and she is more likely to have a positive experience with her activities there
- B** Camp Sunset, because the feedback for the activities is less consistent, so she is more likely to have a positive experience with her activities there
- C** Camp Walden, because the feedback for the activities is more consistent and she is more likely to have a positive experience with her activities there
- D** Camp Walden, because the feedback for the activities is less consistent, so she is more likely to have a positive experience with her activities there

SESSION
1

This question has three parts. Be sure to answer all parts of the question.

18. The length of a rectangle is 4 units more than 3 times its width.
- Write an equation in terms of the width, w , that represents the perimeter, P , of the rectangle. Write your equation in its simplest form.
 - If the width of the rectangle is 10 units, what is the perimeter, in units? Show your work or explain how you know.

A second rectangle has a length of 15 units and a perimeter of 64 units.

- What is the width, w , in units, of the second rectangle? Use an equation to show your work or explain how you know.

19. There are 12 boys and 14 girls in Mr. Rowe's class. Each week, Mr. Rowe puts pieces of paper with each student's name in a box and randomly pulls one out. The chosen student spins the arrow on the spinner shown.

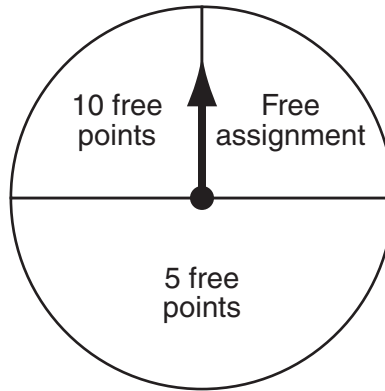

Which expression can be used to find the probability that this week a boy will be chosen and the arrow will land on "Free assignment"?

- A $\frac{12}{26} \times \frac{1}{4}$
- B $\frac{12}{26} + \frac{1}{4}$
- C $\frac{12}{14} \times \frac{1}{4}$
- D $\frac{12}{14} + \frac{1}{4}$

20. Mario has a statue that consists of $\frac{1}{10}$ tin and $\frac{1}{4}$ lead. The rest of the statue consists of copper.

What fraction of the statue consists of copper?

A $\frac{6}{7}$

B $\frac{7}{10}$

C $\frac{13}{14}$

D $\frac{13}{20}$



21. This graph shows the relationship between the time, in seconds, and the height of the bottom of an elevator, in meters, as the elevator moves upward.

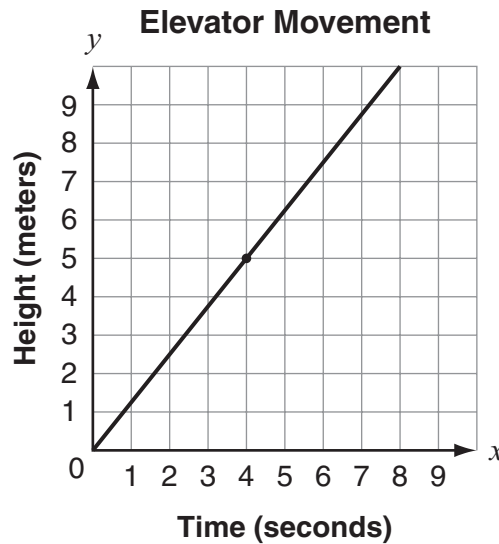

What does the point (4, 5) on this graph represent?

- A** The bottom of the elevator is at a height of 4 meters after moving upward for 5 seconds.
- B** The bottom of the elevator is at a height of 5 meters after moving upward for 4 seconds.
- C** The elevator is moving upward at a speed of 4 meters per second after 5 seconds.
- D** The elevator is moving upward at a speed of 5 meters per second after 4 seconds.

- 22.** Samantha has \$22 to buy one binder and some packages of paper. One binder costs \$4, and packages of paper cost \$3 each. Which inequality can be used to find p , the number of packages of paper Samantha can buy along with the binder?
- A** $4p + 3 \leq 22$
 - B** $4p + 3 \geq 22$
 - C** $4 + 3p \leq 22$
 - D** $4 + 3p \geq 22$





**DO NOT
TURN PAGE**

Mathematics Session 2

DIRECTIONS



Today you will take a test in mathematics. For this test, you will answer selected-response and constructed-response questions. Some of the questions may look different from test questions you have seen before, and some may ask about material that is new to you, but it is important to do your best. If you are not sure of the answer to a question, you should still try to answer it.

You **MAY** use a calculator to answer the questions in this session.

23. Which sentence describes a proportional relationship between the two sets of values?
- A Jarrod paid \$17.00 for 2 ink cartridges and \$59.50 for 7 ink cartridges.
 - B Victoria paid \$14.40 to mail 3 packages and \$21.60 to mail 5 packages.
 - C Sandra downloaded 8 songs in 12 minutes and 14 songs in 22 minutes.
 - D Michael read 18 pages in 9 minutes and 36 pages in 20 minutes.

Use the information below to answer questions 24 and 25.

This scale drawing shows the side and rear views of the storage space of a rental truck.

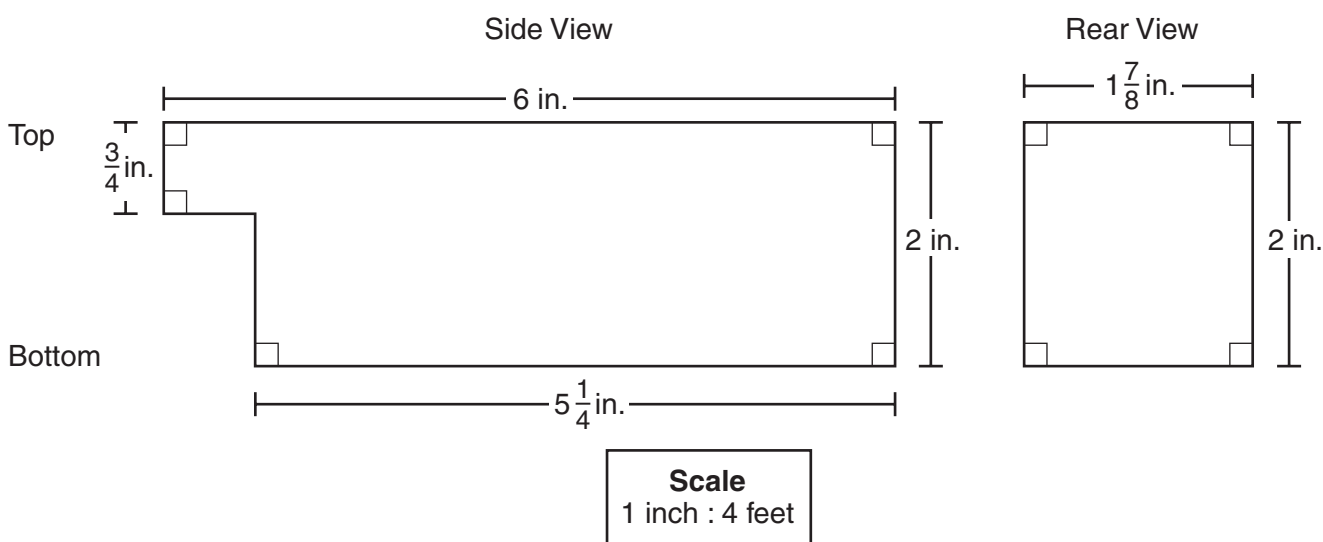



- 24.** Tristan is going to determine the actual floor area of the storage space of the truck.

Based on the dimensions in the scale drawing, what units should he use for the floor area of the storage space?

- A** feet
 - B** inches
 - C** square feet
 - D** square inches
- 25.** Barney wrote this expression for the volume, in cubic feet, of the storage space.

$$(4)(4)(4)\left[6(2) - \frac{3}{4}\left(1\frac{1}{4}\right)\right]$$

Four students evaluated Barney's expression. Which student's statement about Barney's expression for the volume of the storage space is true?

- A** Albert says the expression is correct.
- B** Felicia says the expression is missing a factor of $(4)(2)\left(1\frac{7}{8}\right)$.
- C** Leia says the expression is missing a factor of $(2)\left(1\frac{7}{8}\right)$.
- D** Trey says the expression is missing a factor of $1\frac{7}{8}$.





26. Todd wants to buy a bagel with a filling and a jam.
- The bagel choices are plain or wheat.
 - The filling choices are cream cheese or almond butter.
 - The jam choices are grape or strawberry.

Todd made this tree diagram to show the probability of randomly choosing a bagel, filling, and jam.

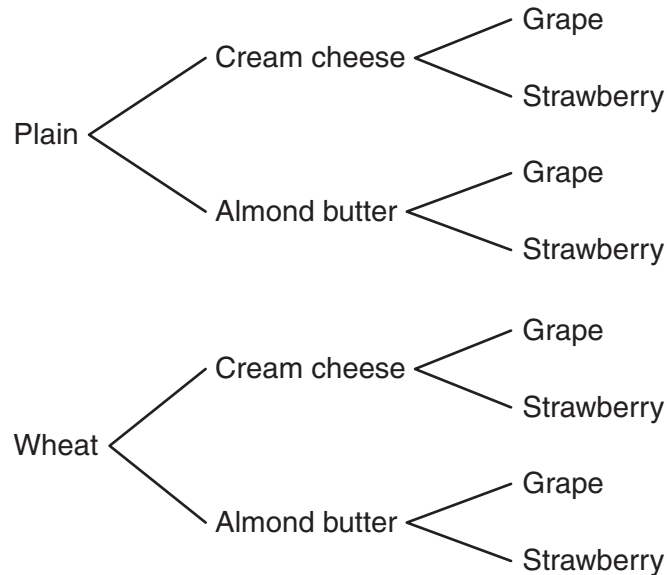

What is the probability that Todd will choose a bagel with cream cheese and strawberry jam?

- A $\frac{1}{8}$
- B $\frac{1}{4}$
- C $\frac{1}{2}$
- D $\frac{3}{4}$



- 27.** Four students conducted a survey about sports preferences at their middle school. Each student asked participants in their survey the same questions.
- Brian surveyed all the students in school clubs.
 - Ellen surveyed 10 different students in all the classes that he had in the morning.
 - Karter surveyed all the seventh graders who were eating sandwiches in the cafeteria at lunchtime.
 - Olivia surveyed each fifth person from a list containing alphabetized names of the students in the school.

Which student's survey would be **most** representative of sports preferences at the school?

- A** Brian's survey
- B** Ellen's survey
- C** Karter's survey
- D** Olivia's survey



28. Consider this cube.

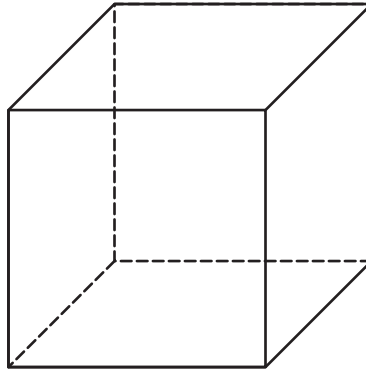

Which figure **cannot** be created from a plane section of the cube?

- A triangle
- B hexagon
- C octagon
- D trapezoid



This question has two parts. Be sure to answer all parts of the question.

- 29.** Paul drew two circles. One circle has a radius of 8 centimeters and the other has a radius of 12 centimeters, as shown.

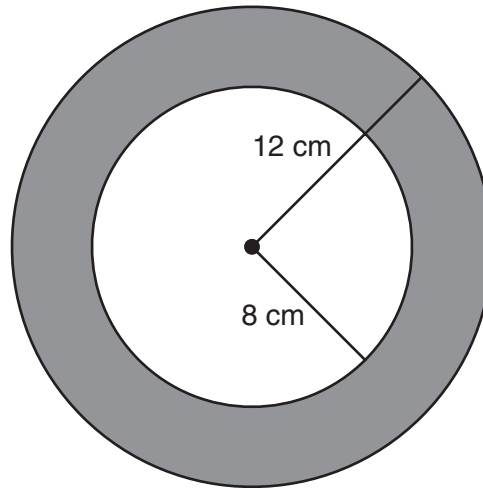

Paul says that the area of the shaded section between the two circles is 16π square centimeters because $A = \pi(12 - 8)^2 = 16\pi$.

- Use words or numbers to explain the error that Paul made in his calculation.
- What is the area, in square centimeters, of the shaded area between the two circles? Use 3.14 for π . Show your work or explain how you know.



30. A local bowling team participates in a two-day tournament and records the scores for each team member on both days. The scores for both days are represented in these box-and-whisker plots.

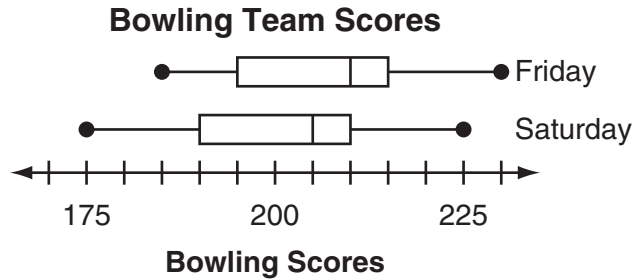

Based on the box-and-whisker plots, which statement is true?

- A The scores on Friday and the scores on Saturday have the same median and interquartile range.
- B The scores on Friday have a greater median and a greater interquartile range than the scores on Saturday.
- C The scores on Friday have a greater interquartile range than the scores on Saturday, but both data sets have the same median.
- D The scores on Friday have a greater median than the scores on Saturday, but both data sets have the same interquartile range.



31. This graph shows the cost of renting a canoe.

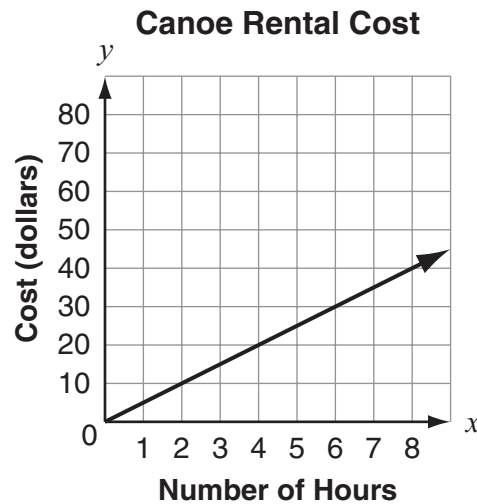

Based on the graph, which statements are true about the cost of renting a canoe? Select the **three** correct answers.

- A It costs \$5 to rent a canoe for 1 hour.
- B It costs \$2 to rent a canoe for 10 hours.
- C The unit rate is 5 hours of rental per dollar.
- D The constant of proportionality for the relationship is 5.
- E The cost of the rental is proportional to the number of hours rented.

SESSION
2

32. A store receives a shipment of boxes of tea. The total mass of the shipment is 6 kilograms.

- Each box of tea has a mass of 0.040 kilogram.
- Boxes of green tea make up 18% of the shipment.

How many boxes of green tea were in the shipment?

- A 7
- B 27
- C 58
- D 108



33. A large wheel has a diameter of approximately 13 feet, as shown.

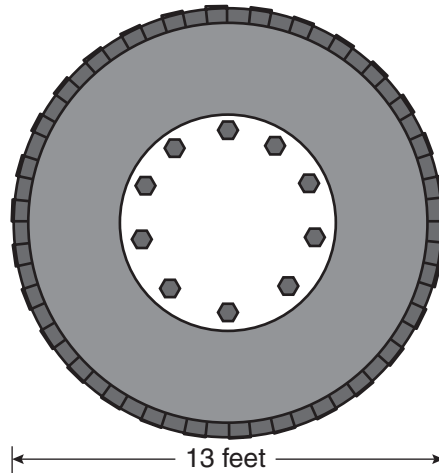

What is the approximate distance, in feet, traveled after one complete rotation of this wheel? Use 3.14 for π .

- A 20 feet
- B 41 feet
- C 82 feet
- D 133 feet

SESSION
2

34. An ice-cream shop manager lowered the price for a single scoop of ice cream from \$2.50 to \$2.00.

What is the percent of decrease in the price?

- A 20%
- B 25%
- C 50%
- D 80%



- 35.** A total of 800 people register to participate in a race. Each participant is given a colored T-shirt to wear in the race. Before the race starts, Aiden records the colors of 32 randomly selected participants' shirts. The results are shown in this table.

Race Shirts

Color	Number of Participants
Red	4
Yellow	12
Purple	10
Orange	6

Based on the results in the table, what is the total number of participants expected to have yellow shirts?

- A** 200
- B** 300
- C** 375
- D** 480



This question has three parts. Be sure to answer all parts of the question.

36. A shoe company has this monthly budget for expenses:

- salaries: $\frac{2}{5}$ of total expenses
- rent: $\frac{1}{3}$ of total expenses
- utilities: $\frac{1}{6}$ of total expenses

The remaining fraction of the total monthly budget for expenses is applied toward miscellaneous expenses.

a. What fraction of the total monthly budget for expenses is applied toward miscellaneous expenses? Use words or numbers to justify your answer.

In April, the budget for miscellaneous expenses was \$8,520.

b. What was the total amount, in dollars, budgeted for all the expenses in April? Use words or numbers to justify your answer.

In May, the budget for salaries was \$45,000.

c. What was the total amount, in dollars, budgeted for **utilities** in May? Use words or numbers to justify your answer.



37. This graph shows the relationship between the time Alec reads and the number of words he reads.

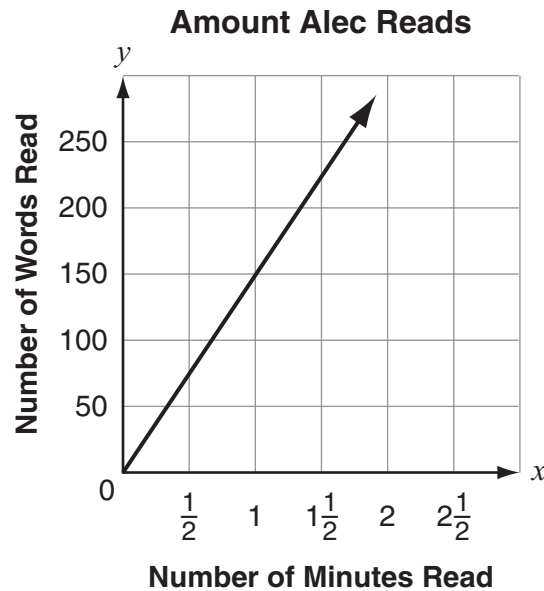

Which point on the graph represents the number of words Alec reads per minute?

- A (1, 100)
- B (1, 150)
- C (100, 1)
- D (150, 1)



38. Cho left a 20% tip on her \$25.70 dinner bill.

Which expression does **not** represent the total amount that Cho paid?

- A $1.2(25.70)$
- B $25.70\left(\frac{20}{100}\right)$
- C $25.70 + 5.14$
- D $25.70 + 25.70(0.2)$



Use the problem below to answer questions 39 and 40.

Kate bought a sketch notebook, a box of 12 colored pencils, a package of 15 erasers, and a box of 13 pastel chalk sticks.

- The box of colored pencils cost \$9.01.
- The package of erasers cost \$0.98.
- The box of pastel chalk sticks cost \$5.01.
- The sales tax rate for all the items is 8%.
- The amount of sales tax was \$1.62.
- The total cost was \$21.87.

What is the cost of the sketch notebook?

39. What information is **not** necessary to solve the problem?

- A the sales tax rate
- B the cost of the package of 15 erasers
- C the cost of the box of 12 colored pencils
- D the cost of the box of 13 pastel chalk sticks



40. In Heather's solution to the problem, she wrote and solved an equation. Her work is shown.

- Step 1:
 $1.08(x + 9.01 + 0.98 + 5.01) = 21.87$
- Step 2:
 $1.08x + 1.08(9.01) + 1.08(0.98) + 1.08(5.01) = 21.87$
- Step 3:
 $1.08x + 9.73 + 1.06 + 5.41 = 21.87$
- Step 4:
 $1.08x = 5.67$
- Step 5:
 $x = 5.25$

The cost of the sketch notebook is \$5.25.

Is Heather's solution correct?

- A** Yes, it is correct.
- B** No, because in step 5 the 5.25 should be 6.12.
- C** No, because in step 4 the 5.67 should be 1.62.
- D** No, because in step 2 only the x should be multiplied by 1.08.





**NEW MEXICO MEASURES
OF STUDENT SUCCESS AND
ACHIEVEMENT**

16 Digit Static Barcode